

Performance Benefits

Cleveland Motion Controls Slim Cell Transducer is part of the Cleveland-Kidder® Tension Transducer family. With a unique new low-profile design, it sets the standard for either new machinery or for retrofits where space is tight. With a dust sealed, corrosion resisting, water resisting design, it is ideal for use in demanding industrial environments.

The Slim Cell Transducer can be used with either rotating shafts or dead shafts and has a flat cylindrical shape. It is designed to reduce the required side-frame-to-side-frame width of the machine. It is also an improved alternative to the UPB style load cell because it can be rotated so that the maximum tension load output is obtained at any web force direction. (A UPB load cell's output is a function of the web force direction and is severely reduced in some orientations.)

The Slim Cell includes a small diameter solid lubricant bearing with very low friction. It is ideal for low tension applications with rotating shafts where the size of the bearing and bearing friction become a major contributing component to the web tension. Shafts are easy to mount. Shaft adapters are provided to accommodate standard shaft diameters. The shaft fits into the

adapter bore and it is held in place with set screws. This eliminates the need for a precision press fit.

Design Features

Cleveland Motion Controls Slim Cell Transducer accommodates any web path. To orient the load cell, just loosen the three mounting bolts, then rotate the load cell body so that the orientation sign is aligned with the bisector of the wrap angle.

The Slim Cell is made of corrosion resisting stainless steel and it is completely sealed to resist water migration. It utilizes a low friction labyrinth seal. The bearing utilizes a solid lubricant, ideal for vacuum application, providing for lifetime lubrication and low friction.

Slim Cell design enables it to be mounted either inside or outside of the machine frame. The Slim Cell is typically applied in pairs, one on each side of the machine. A pillow block style bracket is also available as an option. The Slim Cell Transducer has force ratings from 10 to 1000 lbs. (45 N to 4500 N), accommodating a wide range of tensions. The load cell's ability to accommodate such a wide tension range makes it very adaptable to a number of web tension applications.

LOW PROFILE TRANSDUCER (LOAD CELL)

SLIM CELL

Low profile load cell for use with either rotating shafts or dead shaft rollers

- Low profile design reduces width requirements of machine frame.
- Low friction bearing design ideal for low tension applications.
- Extends usable tension range of your machine (by measuring both low and high tensions).
- Competitively priced alternative to UPB style load cells.
- Maintenance-free solid lubricant bearing ideal for use in vacuum environments.
- Easily oriented to any web path by merely rotating the transducer (if the wrap angle changes), no remounting necessary.
- Available in 2 sizes and 7 different capacities (10 to 1,000 lb.) (45 N to 4,500 N).
- Designed to comply with NEMA 4x, IP65 standards.
- Completely sealed—corrosion resisting, chemical resisting (Stainless Steel 410) water resisting, and dust sealed.
- Accommodates standard roller-shaft diameters.
- 500-1000% Overload Ratings.
- Optional pillow block style mounting bracket.
- CE compliant.



LOW PROFILE TRANSDUCER (LOAD CELL)

SLIM CELL

Cleveland-Kidder®

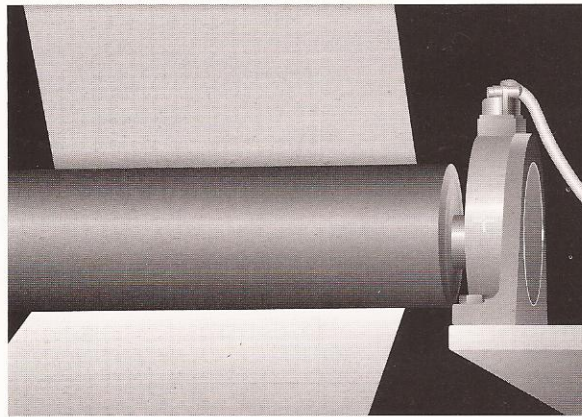

Corrosion Resisting Material:
Made from 410 Stainless Steel

Labyrinth Seal:

- Accommodates angular displacement
- Very low friction
- Maintenance-free

Shaft Adaptor with Set Screws:

- Insures that shaft is precisely locked in position
- Accommodates various shaft diameters

**Overload Stops: 500 to 1000% Ultimate
Overload depending on load cell rating**

Strain Gages:

- Mounted on dual cantilevered beams
- Negligible displacement
- Temperature compensated
- 100 mV output at full load

Connector:
Water tight

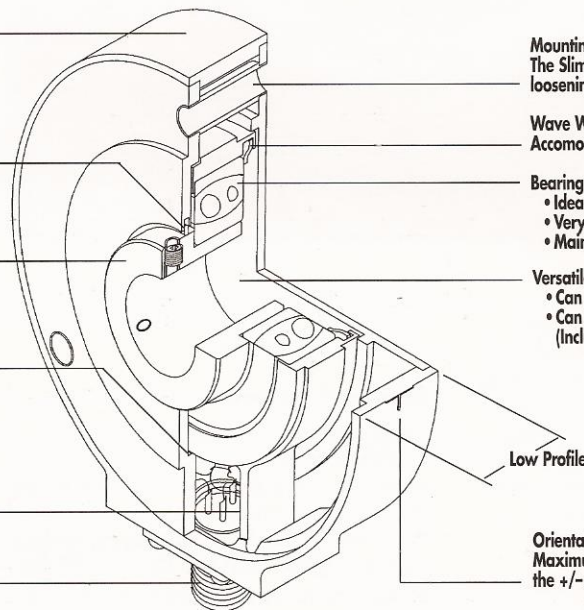

Mounting Holes:
The Slim Cell can be rotated 60 degrees either direction by loosening the mounting bolts to insure proper orientation

Wave Washer:
Accommodates shaft expansion

Bearing with solid lubricant:

- Ideal for vacuum application
- Very low friction
- Maintenance-free

Versatile Back Plate:

- Can be flipped over to use the mounting pilot
- Can be provided with a through hole (Includes labyrinth ring seal)

Low Profile

Orientation Sign:
Maximum signal output is obtained by orienting the +/- sign along the bisector of the wrap angle

Table 1: Slim Cell Ratings

Weight lb. (kg.)	SLM 1	SLM 2
Slim Cell	2.7 (1.3)	6.3 (2.9)
Slim Cell + Bracket	5.5 (2.5)	11.1 (5.1)

SIZE	MWF (lb.)	Linear Overload (%)*	Ultimate Overload (%)**
SLM1	10	400	800
	25	400	800
	50	400	1000
	100	300	1000
	250	300	1000
SLM2	500	150	500
	1000	200	1000

* Linear overload: Maximum force applied on the transducer before hitting the safety stops. The output is linear until that point.

** Ultimate overload: Maximum force applied on the transducer without risking permanent deformation.

INDUSTRIAL PRODUCTS

7550 Hub Parkway
Cleveland, Oh 44125-5794
Tel: 216-524-8800 or (800) 321-8072
Fax: 216-642-2100
Visit Us: www.cmcccontrols.com

CMC Cleveland Motion Controls
An IMC Company

LOW PROFILE TRANSDUCER (LOAD CELL)



Low profile load cell for use with either rotating shafts or dead shaft rollers

Cleveland-Kidder®

PART NUMBER CONFIGURATOR

25	—	0.750	—	SLM 1	—	BF	—	RS
LOAD CELL RATING		ROLLER SHAFT DIAMETER		LOAD CELL BODY SIZE		LOAD CELL BACK PLATE		ROLLER SHAFT TYPE
10 lb. (45 N) 25 lb. (110 N) 50 lb. (225 N) 100 lb. (450 N) 250 lb. (1100 N) 500 lb. (2250 N) 1000 lb. (4500 N)		In. 0.625 0.750 1.000 1.250 1.500 1.750 mm 15mm 20mm 25mm 30mm 35mm 40mm		(See Table 2) SLM 1 SLM 2		(See Table 3 Installation Choices) Blank/Flush BF Blank/Pilot BP Hole/Flush HF Hole/Pilot HP		Rotating (Live) RS Stationary (Dead) SS

ORDERING PROCEDURE:

Slim Cell part numbers are configured according to your requirements:

1. Calculate the Maximum Working Force (MWF) rating from the Sizing Calculation equation. From the Part Number Configurator, select a Load Cell Rating that equals or exceeds the MWF from your sizing calculation. This becomes position 1 of your part number.
2. Refer to Table 2, Slim Cell Body Size: Roller Shaft Diameter vs. Load Cell Rating. Determine the diameter of your roller shaft and select the Slim Cell Body Size (SLM 1 or 2) that accommodates both your load cell rating and shaft diameter. Refer to the Part Number Configurator. The Roller Shaft Diameter and Load Cell Body Size become positions 2 and 3 of your part number. (Note: It may be necessary to turn down the end of your roller shaft on a lathe to accommodate the roller diameter choices offered.)
3. Refer to Table 3, Installation Choices and the Part Number Configurator. The Slim Cell may be mounted inside or outside the machine frame, or mounted on top by utilizing the optional pillow-style mounting bracket. The Slim Cell back plate is supplied with a through hole (H) or blank, without a through hole (B). The Slim Cell back plate is offered either with an alignment pilot (P)

or flush mount (F). Determine the type of back plate required for your installation (BF, BP, HF, HP). The Load Cell Back Plate becomes positions 4 of your part number.

4. Determine if your roller shaft is rotating or stationary. The Roller Shaft Type becomes position 5 of your part number.

Example: If you calculate a MWF of 21 lb., you have a rotating roller shaft and your shaft diameter is 0.750 inches. Your installation does not require a through hole in the back plate and you are flush mounting the Slim Cell inside the machine frame. Your part number is 25-0.750-SLM1-BF-RS.

5. If you require the optional mounting bracket, order it separately. Refer to the chart below:

Mounting Bracket	Part Number
For Slim Cell Size 1 (SLM 1)	SLM BR 1
For Slim Cell Size 2 (SLM 2)	SLM BR 2

6. Obtain pricing and delivery information by contacting a CMC Sales Representative, Distributor or the factory.

INDUSTRIAL PRODUCTS

7550 Hub Parkway
Cleveland, Oh 44125-5794
Tel: 216-524-8800 or (800) 321-8072
Fax: 216-642-2100
Visit Us: www.cmccontrols.com



SIZING CALCULATION

- T = Max Tension
- A = Wrap Angle (Degrees)
- W = Roll Weight
- B = Angle of Tension Force (Degrees)
- K = Overload for Transients (nominal 1.5 for most applications)
- MWF = Maximum Working Force (Used to select the proper force rating of the transducer)

$$MWF^* = T \times K \times \sin(A/2) \pm (W/2) \times \sin(B)^{**}$$

* The MWF calculation defines the force on each individual load cell

** If Angle B is below horizontal, use (+) in calculation. If Angle B is above horizontal, use (-) in calculation.

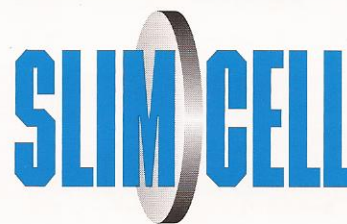
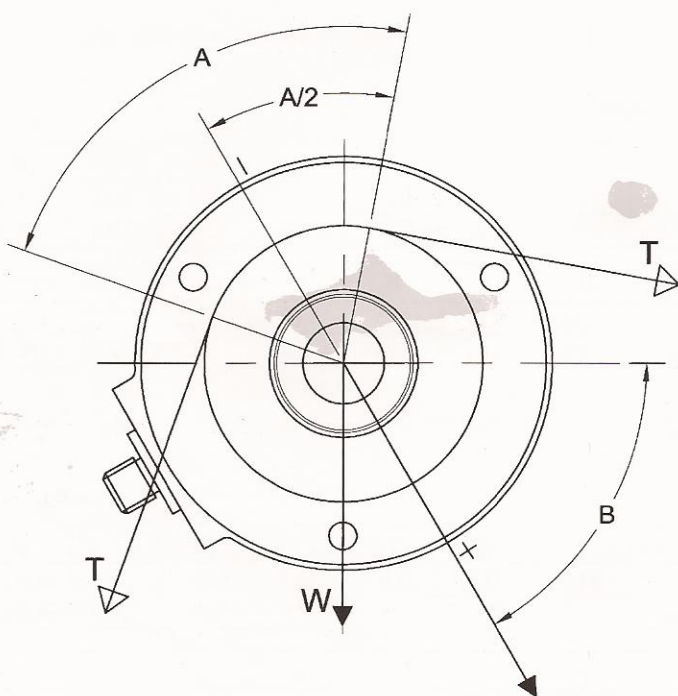

Low profile load cell
for use with either
rotating shafts or
dead shaft rollers

Table 2: Slim Cell Body Size (Roller Shaft Diameter vs. Load Cell Rating)

Load Cell Rating (lbs.)	Roller Shaft Diameter											
	15mm	0.625"	0.750"	20mm	25mm	1.000"	30mm	1.250"	35mm	1.500"	40mm	1.750"
10	SLM 1											
25												
50												
100												
250												
500	SLM 2					SLM 2						
1000												

INDUSTRIAL PRODUCTS

7550 Hub Parkway
Cleveland, Oh 44125-5794
Tel: 216-524-8800 or (800) 321-8072
Fax: 216-642-2100
Visit Us: www.cmcontrols.com

LOW PROFILE TRANSDUCER (LOAD CELL)

Cleveland-Kidder®

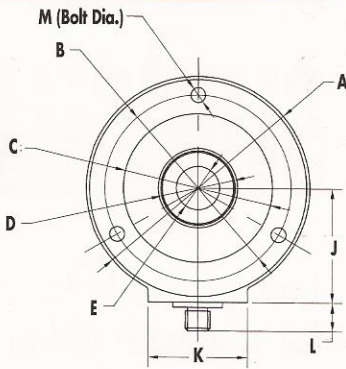

Slim Cell (alone)

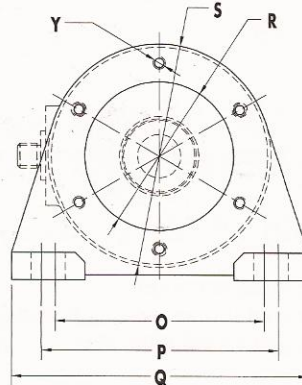
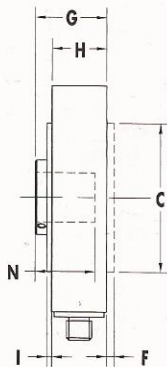

Mounting Bracket (with Slim Cell)

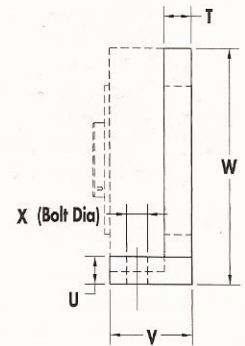

DIMENSION TABLES

Dimensions In Inches*

SIZE	A	B	C	D	E**	F	G	H	I	J	K	L	M
SLM1	4.50	3.75	2.996-3.000	1.50	-	0.12	1.31	1.02	0.07	2.30	2.00	0.65	1/4 (3)
SLM2	5.80	4.75	4.196-4.200	2.46	-	0.14	1.70	1.32	0.10	3.05	2.50	0.65	3/8 (3)

SIZE	N	O	P	Q	R	S	T	U	V	W	X	Y***
SLM1	1.02	4.22	4.78	6.00	3.000-3.006	4.50	0.55	0.55	1.60	4.75	3/8 (2)	1/4 (3)
SLM2	1.36	5.50	6.50	8.00	4.200-4.206	5.80	0.65	0.65	2.00	6.2	1/2 (2)	3/8 (3)

* For dimensions in inches, allow 2.5 inch clearance for cable connector.

** See Table 2 for permissible Shaft Diameter. Bore Diameter is typically between Nominal Diameter +0.0007 and +0.0017 inch.

*** Bolts supplied with bracket

Dimensions In Millimeters*

SIZE	A	B	C	D	E**	F	G	H	I	J	K	L	M
SLM1	114.3	95.3	76.10-76.20	38.1	-	3.0	33.3	25.9	1.8	58.4	50.8	16.5	6mm (3)
SLM2	174.3	120.7	106.58-106.68	62.5	-	3.6	43.2	33.5	2.5	77.5	63.5	16.5	8mm (3)

SIZE	N	O	P	Q	R	S	T	U	V	W	X	Y***
SLM1	25.9	107.2	121.4	152.4	76.20-76.35	114.3	14.0	14.0	40.6	120.6	10mm (2)	1/4 (3)
SLM2	34.5	139.7	165.1	203.2	106.68-106.83	174.3	16.5	16.5	50.8	157.5	12mm (2)	3/8 (3)

* For dimensions in millimeters, allow 64 mm clearance for cable connector.

** See Table 2 for permissible Shaft Diameter. Bore Diameter is typically between Nominal Diameter +0.018 and +0.043 mm.

*** Bolts supplied with bracket

ACCESSORIES

Load Cell Cables* – The load cell cable end is provided with a straight or right angle connector as specified. The controller end is provided with tinned leads. The controller end of the cable can be cut to length if the standard length provided is not the exact length required.

Cable Length	Part Number - Straight Connector	Part Number - Right Angle Connector
20 Feet	MO-01948-020	MO-01957-020
25 Feet	MO-01948-025	MO-01957-025
50 Feet	MO-01948-050	MO-01957-050
75 Feet	MO-01948-075	MO-01957-075
100 Feet	MO-01948-100	MO-01957-100
150 Feet	MO-01948-150	MO-01957-150

* Cables are not washdown-duty. For washdown-duty cables consult CMC.

INDUSTRIAL PRODUCTS

7550 Hub Parkway
Cleveland, Oh 44125-5794
Tel: 216-524-8800 or (800) 321-8072
Fax: 216-642-2100
Visit Us: www.cmccontrols.com

CMC Cleveland
Motion Controls
An IMC Company

LOW PROFILE TRANSDUCER (LOAD CELL)

Cleveland-Kidder®

SLIM CELL

**TABLE 3:
Installation Choices**

62 degrees of angular
alignment with bolt in position

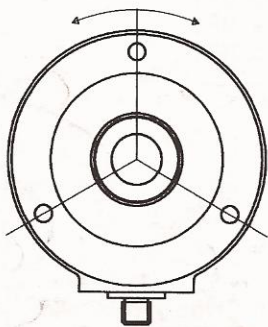

	Inside Frame	Outside Frame	With Mounting Bracket
Blank Back Plate			
Back Plate With Hole			

SPECIFICATIONS

Material:	Body and Side Plates—Stainless Steel 410
Gage Resistance:	Each transducer contains half a bridge having a nominal end-to-end resistance of 440-480 Ohms.
Gage Factor:	100 nominal
Excitation Voltage:	10 VDC or VAC (rms) maximum
Output Signal @ Rated M.W.F.:	100-150 mV nominal / transducer, 200-300 mV nominal / pair (With 10 VDC or VAC rms excitation voltage)
Operating Temperature Range:	0°F to 200°F
Sensitivity Change with Temp.	Less than 0.02% of rated output typical
Humidity:	95% R.H.
Combined Non-linearity and hysteresis:	±0.5% maximum of rated output
Repeatability:	±0.2% maximum of rated output
“MS” Connectors:	MS-3102E-10SL-3P (Sealed 3 Pin Connector)
Input Impedance required: (Transducer Signal Amplifier if not CMC supplied)	5K Ohms per transducer
Output impedance:	880 Ohms
Alignment:	The Slim Cell bearing can accommodate up to 5 degrees angular displacement.

INDUSTRIAL PRODUCTS

7550 Hub Parkway
Cleveland, Oh 44125-5794
Tel: 216-524-8800 or (800) 321-8072
Fax: 216-642-2100
Visit Us: www.cmcontrols.com

CMC Cleveland
Motion Controls
An IMC Company